

EXPRESS ALIGNMENT BY FIXTURLASER

Just Align It.

With Fixturlaser GO.



EXPRESS ALIGNMENT BY FIXTURLASER



Just Align It. With Fixturlaser GO.

Why complicate things? Using laser based alignment systems will make your everyday life so much easier, compared to using the traditional methods, such as dials, straight edges, etc. Fixturlaser GO is the latest addition to the Express Alignment product range, with the typical characteristics of a laser based alignment system from Fixturlaser. It is an uncomplicated alignment tool for every maintenance professional that is concerned about the machines' length of life.

Measuring and Aligning with Fixturlaser GO

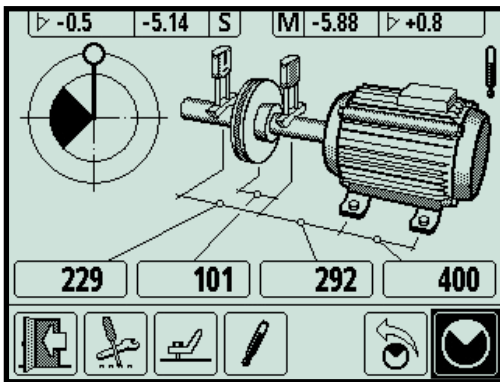

Measure



When the fixtures are mounted and all distance values have been entered, you are ready to start taking measurement points. The system needs three measurement points with a minimum angle of 45° between readings. **The rotation guide** indicates with black or white fields if you are in a permitted area or not.

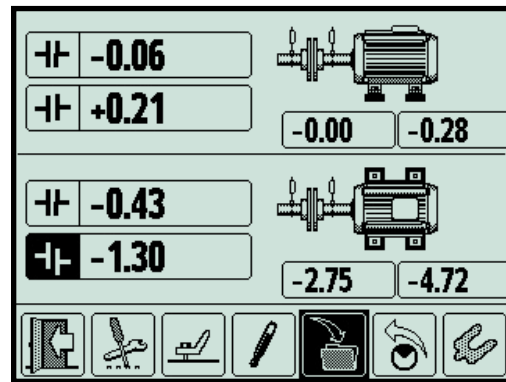

Results



The measurement result screen shows **coupling values and foot values for horizontal and vertical direction**. The result field is enhanced with symbols indicating angular and/ or offset errors.

Align

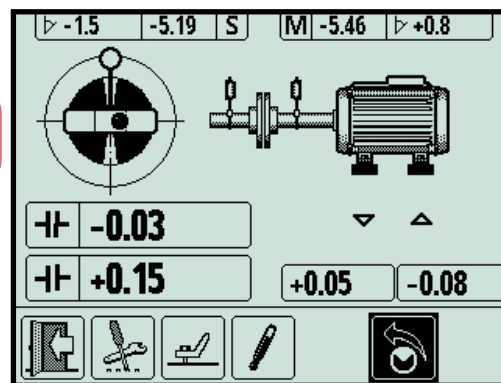

Proceeding to alignment, you start out with rotating the shafts to the 12 or 6 o'clock position in order to make adjustments in the vertical direction. To reach the right position, you have **the angle guide** to your help. When shimming the machine, the live values will indicate when the machine is within tolerance. Also, **the arrows by the machine's feet** will show in which direction the machine needs to be moved.

Continue by rotating the shafts to the 3 or 9 o'clock position for adjustments in the horizontal direction. Once again, **the angle guide** will help you with reaching the right position. Move the machine until the values for both angular and parallel alignment are within tolerance, where **the arrows** again help out with which direction to choose.

Complete the alignment process by rotating the shafts back to the 12 or 6 o'clock position to verify that the machine's alignment status is within tolerance. To confirm the result, redo the measurement.

Fixturlaser GO Features



Several of its features are adopted from the innovative Fixturlaser XA system, which will reduce the time spent on pre-alignment actions, measurement registration, performing the actual alignment, remeasuring to make certain that you have a correctly aligned machine; and, finally, documenting the measurement data.

The pre-mounted fixtures speed up mounting and packing of the fixtures.

Other characteristics facilitating the handling of the system are the icon based user interface, a typical Fixturlaser trademark, now used in our systems for more than 15 years.



The Fixturlaser GO Software Package



Horizontal Alignment



Vertical Alignment



SoftCheck™



Target Values



Memory Manager



The measurements can be transferred to a PC by connecting the display unit to the USB connection. When connected the display unit appears as a mass storage device in your PC. Files are then easily transferred using the Explorer on the PC.

The CCD technology used in the measurement units' extra large detector area (30 mm) minimizes or, in most cases, eliminates the need for rough alignment. This technology also makes it possible to suppress ambient light and it rejects side spots that might interfere with the accuracy of the measurement values.

Line laser combined with the CCD, renders the laser adjustment easier than ever. The measurement units will always be in the right position sideways, and vertical adjustments are easily done by unsnapping the measurement units' snap-on fixtures.



The three LED lights on the display unit indicate whether the couplings are within tolerance (green light), within double tolerance (orange light), or out of double tolerance (red).

Technical Specification

FIXTURLASER GO - COMPLETE SYSTEM

Weight (incl. all standard parts): 6.8 kg (15 lbs)

Storage Temperature: -20 to 70°C (-4 to 158°F)

CASE

Material:	High Impact ABS Plastic
Sealing:	Dust, water (5m/16 feet), and air tight with air pressure compensation valve
Drop Test:	3 m (10 feet) on to concrete floor
Dimensions:	400 x 320 x 170 mm (15.7 x 12.6 x 6.7 inch)

DISPLAY UNIT

Housing Material:	High impact ABS plastic
Operating Temp:	-10 to 50°C (14 to 122°F)
Storage Temp:	-20 to 70°C (-4 to 158°F)
Relative Humidity:	10 – 90%
Weight:	0.7 kg (1.54 lbs) with batteries
Dimensions:	205 mm x 116 mm x 56 mm (8.1 in x 4.6 in x 2.2 in)
Environmental Protection:	IP 54
Flash storage memory:	4 Mb
Display size:	4" diagonal (80 x 60 mm)
Interface:	Membrane Switch Keyboard
Peripherals:	2 RS-485, 1 USB slave port
Power supply:	3 x 1.5V LR-14 (C) Alkaline batteries
Operating Time:	15 hours typical use
LED Indicators:	Green, orange, red for alignment status indication

MEASURING UNITS

Housing Material:	Anodized aluminum and high impact ABS plastic molded over with TPE rubber
Operating Temp:	0 to 50°C (32 to 122°F)
Relative Humidity:	10 – 90%
Weight:	186 g (6,6 oz)
Dimensions:	79 mm x 77 mm x 33 mm (3,1 in x 3,0 in x 1,3 in)
Environmental Protection:	IP 65
Laser:	650 nm class II diode laser
Laser Line Fan Angle:	6°
Laser line width (1/e2):	1,6 mm
Laser line divergence (full angle):	0.25 mrad
Laser Power:	< 1 mW
Measurement distance:	Up to 5m
Detector:	CCD
Detector length:	30 mm (1.2 in)
Detector angular sub tense:	30mrad/m (3mm/100mm per meter)
Detector resolution:	1 µm
Measurement accuracy:	0.3% ± 7 µm
LED Indicators:	Laser transmission and status indicators
Inclinometer resolution:	0.1°
Inclinometer accuracy:	±0.5°
Ambient light protection:	Optical filtering and ambient light signal rejection
Cables:	2 pcs à 2 m (6.5 feet)

SHAFT BRACKETS:

Fixture:	V-fixture for chain, width 20 mm (0,79 in)
Material:	Anodized aluminum
Shaft diameter:	Ø 20 – 175 mm (3/4 in – 6.9 in)
With extension chains	Ø 20 – 450 mm (3/4 in – 18 in)
Rods:	4 pcs 160 mm (6.3 in)



Standard Equipment for Fixturlaser GO

Complete system **Art no 1-0806**

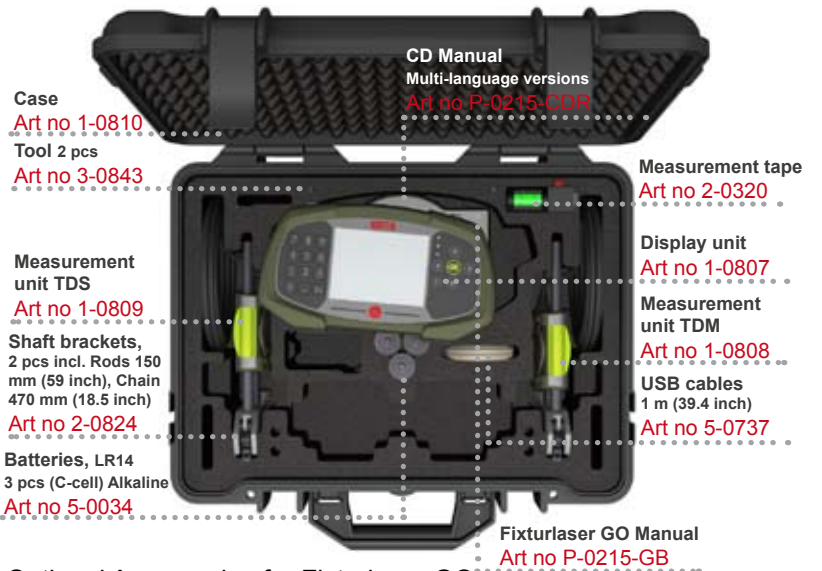

Optional Accessories for Fixturlaser GO

